

Varenummer: 0109072  
 Beskrivelse: Seeger låsering AS 55X3.0  
 Fjederstål  
 Note: Monteres med ZGA tang

## Mål

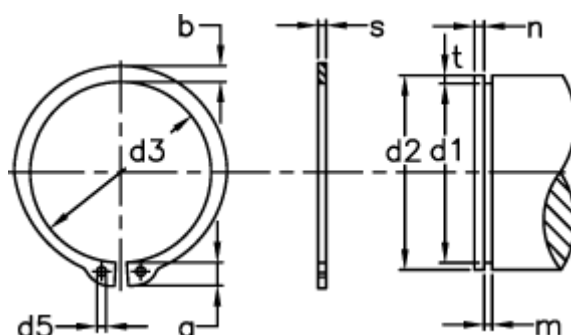

a max	= 8.5	d5 min	= 2.5	s	= 3.00
AN mm <sup>2</sup>	= 252.0	FN kN	= 42.00	t	= 1.50
B	= 2.25	FRg kN	= 25.6	Tang	= ZGA-3
b	= 5.4	FR kN	= 161.0	tol	= -0.08
Betegnelse	= AS 55	g	= 2.5	tol	= +0,46 -1,10
d1	= 52.0	m min	= 3.15	tol	= -0.30
d2	= 55	n abl x 1000	= 9	vægt kg/1000	= 17.00
d3	= 50.8	Nominel træk	= 4.5		